

Dargestellte Ausführung: Form KV, Spannrichtung R durch Rechtsdrehung

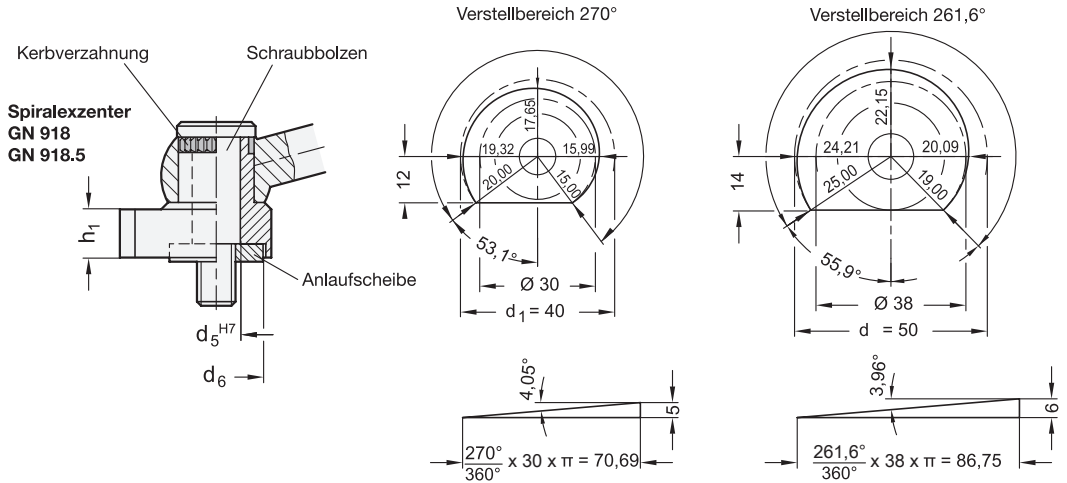

Spannriegel
GN 918.1
GN 918.6

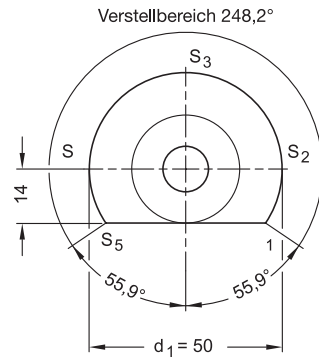
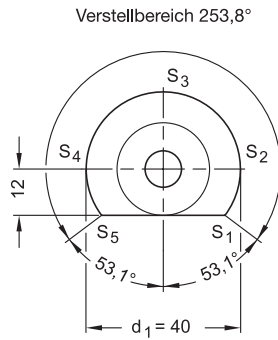
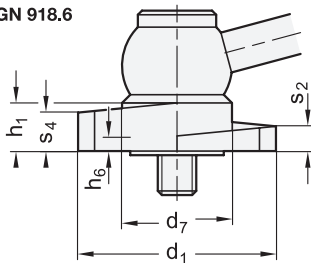

Spannriegel
GN 918.2
GN 918.7

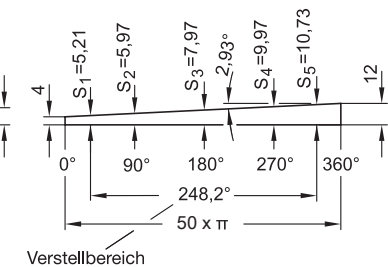
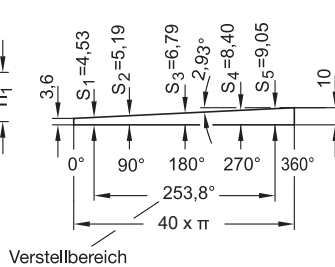
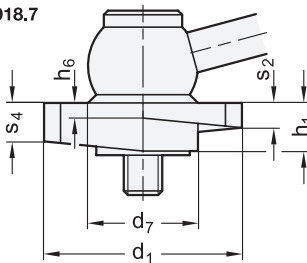

$d_1 - 0,5$	d_5	d_6	d_7	h_1	h_6
40	10	20	24	10	3,6
50	12	24	28	12	4

1.1
1.2
1.3
1.4
2.1
2.2
2.3
2.4

