

## Function

Fixed firmly to the housing or the operating element, the pointer shaft with the red pointer is mounted at the centre of the position indicator. The red pointer therefore shows the revolution of the spindle at a ratio of 1 to 1, at the same time turning in the same direction as the spindle. The pendulum is positioned freely on the same pointer shaft, with the pendulum not turning in sync but always held in the same position owing to its force of gravity.

The scale, the gear wheels required for the register and the register itself are mounted on this pendulum. The rotary motion of the operating element is now transferred to the register via a gear wheel fixed to the pointer shaft and via the reduction gearing at the fixed pendulum. Any position (rotary position) of the spindle can now be read with accuracy.

## Use

The outstanding feature of pendulum-type position indicators is that the measuring system is fully integrated in the operating element. During installation, they require no further measures on the machine side.

In principle, these position indicators have been designed solely for attachment to horizontal spindles, but the high precision of the mechanical measurement system (the pendulum system is mounted on ball bearings) and the extremely low centre of gravity allow these to be used also for spindles inclined by as much as 60°.

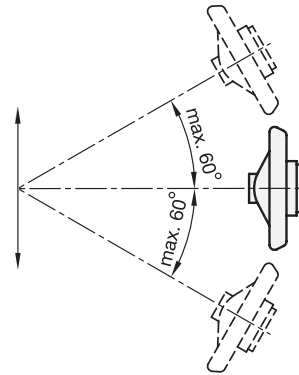

## Selecting the reduction

While the red pointer shows the rotary motion of the spindle at a ratio of 1 to 1, the register shows a numerical value matching the axial displacement of the spindle as factor of the thread pitch.

The parameter of the register is the display value after one revolution starting from the zero position.

The register is available with ascending numerical value by right turn (clockwise) or left turn (anticlockwise).

## Scale

The standard scale has 50 graduation marks without numbers.

Special scales on request

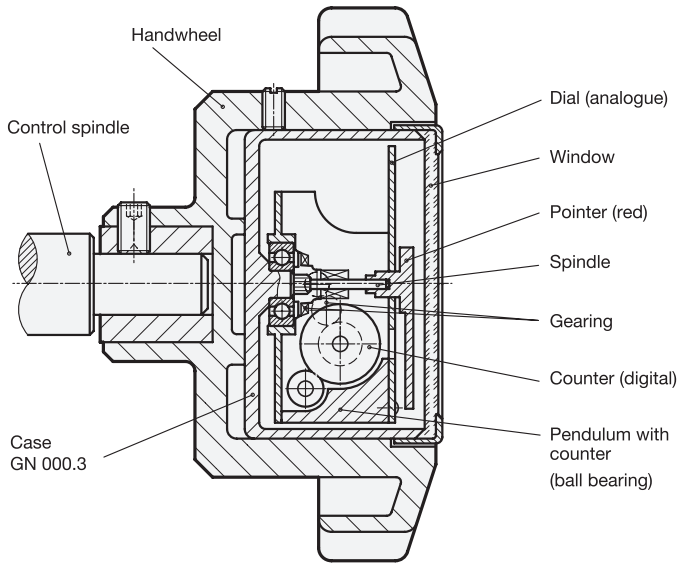

Dial without figures

