

### Construction information

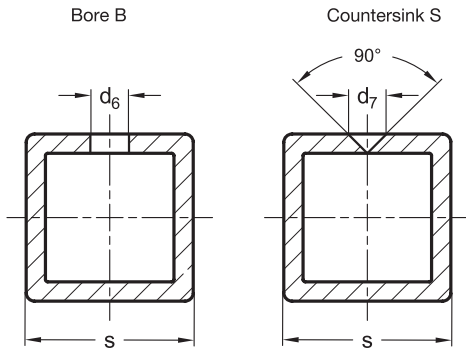

The square dimensions of the locking slide units are designed for construction tubes GN 990. These can be fitted with locking holes (B or S) by the user according to the dimensions specified in the table.

Construction tubes with locking holes can be ordered as standard part GN 990.1 cut to length and completely ready for installation.

s	$d_6 + 0,3$ Bore B (for type R)	$d_7 + 0,3$ Countersink S (for type D)	for locking slides
V 25	B 5	S 2,5	V 25
V 30	B 5	S 2,5	V 30
V 40	B 8	S 4,5	V 40
V 50	B 8	S 4,5	V 50

### Application examples

