

## Mounting holes - outer slide

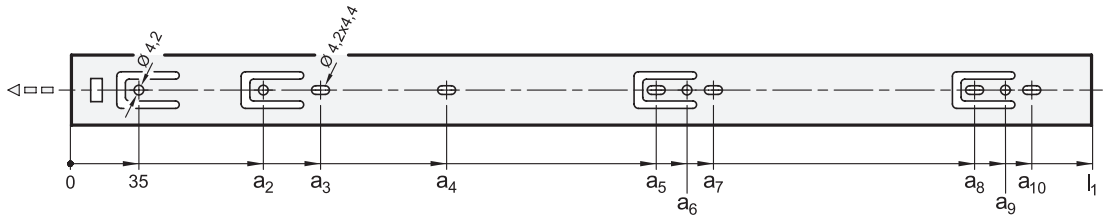

$l_1$	$a_2$	$a_3$	$a_4$	$a_5$	$a_6$	$a_7$	$a_8$	$a_9$	$a_{10}$
250	-	65	-	195	210	225	-	-	-
300	99	129	195	257	272	-	-	-	-
350	99	129	185	259	274	289	-	-	-
400	99	129	-	259	274	-	323	338	353
450	99	129	185	259	274	289	387	402	417
500	99	129	185	291	306	321	451	466	481
550	99	129	185	323	338	353	483	498	513
600	99	129	185	323	338	353	515	530	545
650	99	129	185	355	370	385	579	594	609
700	99	129	185	387	402	417	643	658	673

## Mounting holes - inner slide

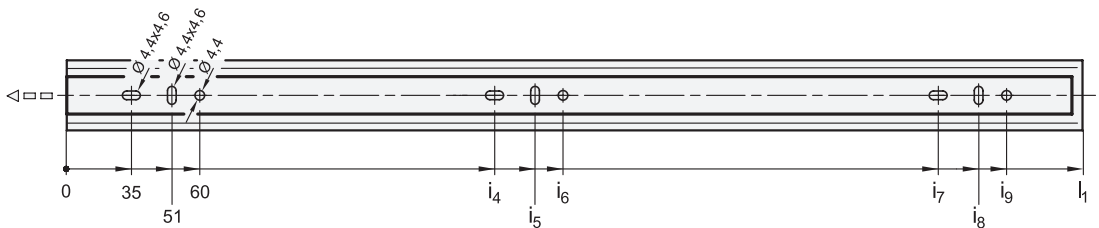

$l_1$	$i_4$	$i_5$	$i_6$	$i_7$	$i_8$	$i_9$
250	195	211	220	-	-	-
300	114	130	139	227	243	252
350	163	179	188	291	307	316
400	163	179	188	355	371	380
450	195	211	220	387	403	412
500	227	243	252	451	467	476
550	259	275	284	483	499	508
600	259	275	284	515	531	540
650	291	307	316	579	595	604
700	323	339	348	643	659	668

## Fastening screws

For the said loading forces  $F_S$  to be absorbed reliably in the surrounding structure, all available through-holes of the outer slide having a diameter ( $\varnothing$ ) of 4.2 and of the inner slide having a diameter ( $\varnothing$ ) of 4.4 must be used. The elongated holes,  $\varnothing 4.2 \times 4.4$  of the outer slide and  $\varnothing 4.4 \times 4.6$  of the inner slide, are used likewise for fastening and facilitate adjustment during mounting when needed. Failure to use fastening screws reduces the specified load capacity accordingly. The following screws can be used for mounting:

Designation - standard		Outer slide	Inner slide
Hexagon socket button head screw	ISO 7380	M 4	M 4
Pan head screw, Phillips	ISO 7045	M 4	M 4
Pan head tapping screw, Phillips	ISO 7049	ST 3,9 / 4,2	ST 3,9 / 4,2

## Rubber stop, locking device in back

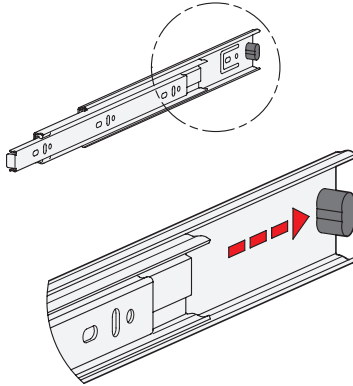

The rubber stops of type F dampen the impact of the slide in the respective end position. This feature minimizes noise development and increases the lifespan. Attached to the slides in a partially concealed, partially visible manner, the stops meet each of the requirements in regard to shape, material, and hardness.

In the back stop position, the rubber stop takes on additionally a locking function, which is noticeable through a slight resistance on opening and closing.

If larger static or dynamic loads occur in the direction of extension, they should be absorbed by external stop elements.

## Detach function

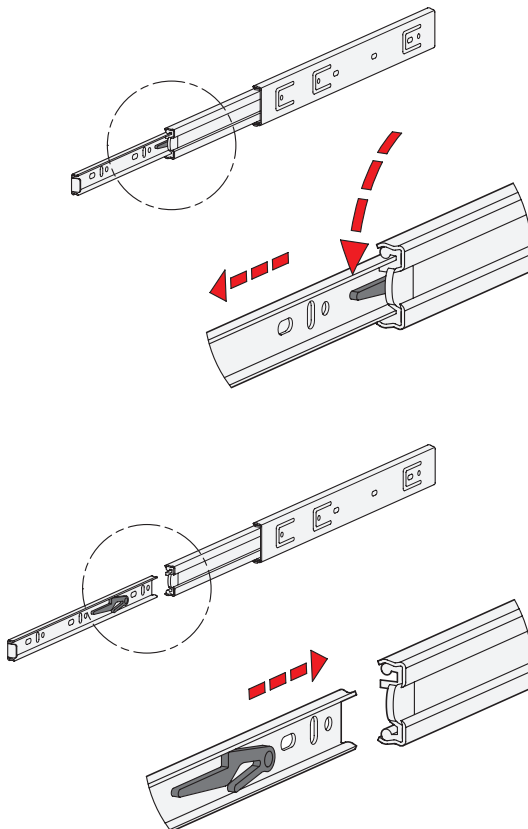

Type F has additionally a detach function through which the extension slides can be completely separated from one another in the area of the middle and inner slide. This feature not only facilitates mounting. It also allows the extension to be quickly removed, for example, when frequent maintenance work is performed on the components located behind.

The telescopic slide can be quickly and easily detached in the extracted position through activation of the release lever, allowing the inner slide to be removed from the front.

For reattaching the slides, the ball cages need to be moved to the front end position. Then the inner slide is inserted to the back end stop where it locks into place automatically.

The protected arrangement of the release mechanism prevents accidental detachment of the slide.

