

2 Type

- N** Normal roller carriage, central arrangement
- R** Radial roller carriage, lateral arrangement
- S** Narrow roller carriage, central arrangement

3 Version

- U** with wiper for floating bearing rail (U-rail)
- X** with wiper for fixed bearing rail (X-rail)

1

Type N										
h_1 Rail	b_1	b_2	b_3	d_1	d_2	h_2	l_1	l_2	m	A/F
18	8,3	16,5	7,2	14	M 5	17	76	62	52	8
28	12,3	24,1	10	22,4	M 6	25	116	102	78	13
43	21	37,5	15	35	M 8	40	148	134	114	15

Type S / Type R																		
h_1 Rail	b_1	b_2		b_3		d_1	d_2	d_3	h_2		h_3	l_1	l_2	m		s	t	A/F
		Type S	Type R	Type S	Type R				Type S	Type R				Type S	Type R			
18	8,3	15	17,3	5,7	8	14	M 5	M 4	9,5	20	4	74	60	20	20	17	8	8
28	12,3	23,8	24,1	9,7	10	22,4	M 6	M 5	15	30	4	94	80	35	36	24,5	10	13
35	16,5	30	30	12	12	28	M 8	M 6	20	36	3	114	100	45	45	29,5	15	15
43	21	37	37,5	14,5	15	35	M 8	M 6	25	45	4	134	120	55	56	38,5	16	15

Specification

- Base body
 - Aluminum (Type N)
 - Steel (Type R / Type S)
zinc plated, blue passivated
- Rollers
 - Anti-friction bearing steel, hardened
 - Ball mounted, sealed (2RS)
 - permanent lubrication
- Wiper
 - Plastic, PUR, gray
 - Steel insert, zinc plated
- RoHS

On request

- Cam roller carriages with more than 3 rollers
- other roller arrangements

Information

Cam roller carriages GN 2424 are combined with cam roller linear guide rails GN 2422 to build linear guide rail systems. They are used in mechanical engineering or jigmaking for the linear movement of plant equipment.

Depending on cam roller carriage type, these can be mounted in axial or radial direction to the roller axes. Also depending on rail type, matching wipers are mounted, with type N featuring additional sealing lips in longitudinal direction.

see also...

- *Structure linear guide rail systems* → Page 1298
- *Cam roller linear guide rails GN 2422* → Page 1301
- *Cam rollers GN 2426* → Page 1304
- *Linear guide rail systems (Technical information etc.)* → Page 1306 ff.

How to order

GN 2424-35-N-X

1	h_1
2	Type
3	Version

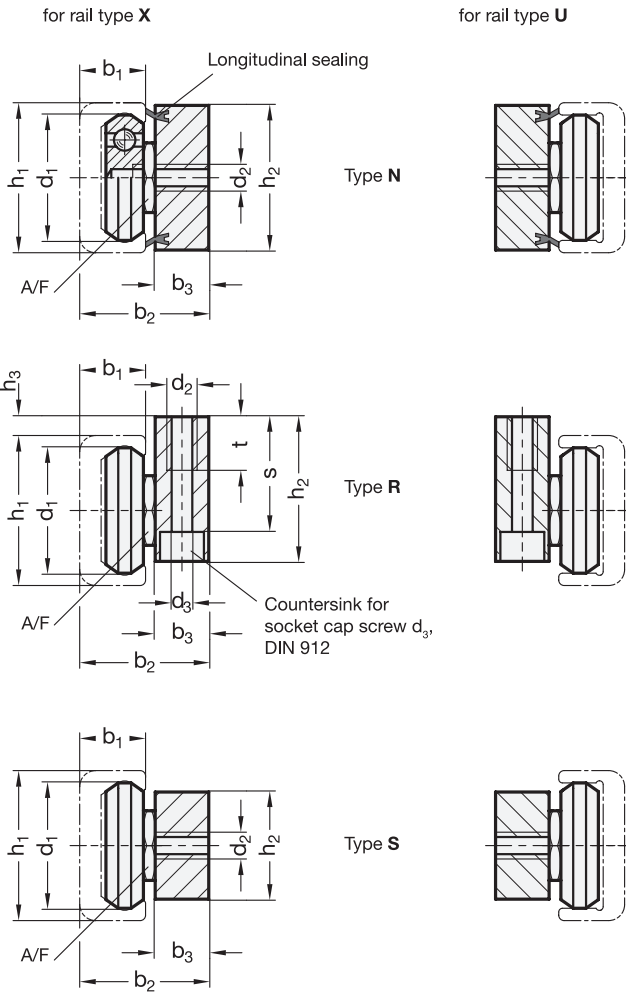

Assembly information

The initial tension or the clearance of the cam roller carriage in the rail can be determined during assembly. Both outer rollers carry the cam roller carriage, with the middle roller (for eccentric adjustment) supporting the carriage on the opposing rail side. Detailed assembly instructions and the necessary tool are included with every cam roller carriage.

If required, the open-end wrench may also be ordered separately (GN 2424.1), with two sizes being available:

$A/F_1 / A/F_2 = 8$ for construction size with $h_1 = 18$, Article No. **GN 2424.1-8-8**

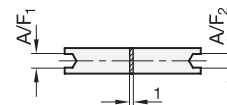

$A/F_1 = 13$ and $A/F_2 = 15$ for construction size with $h_1 = 28 / 35 / 43$,

Article No. **GN 2424.1-13-15**

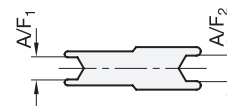

3.1
3.2
3.3
3.4
3.5
3.6
3.7
3.8
3.9

