

## Information

The static load bearing capacity given in the table rests on a test series in which the load has been applied perpendicular to the base plate (without rubber underlay). For the values given in the table, the strain relief may result in minor deformations of the base plate.

Bending and buckling stress which often occurs in practice results in a lower load bearing capacity of the adjustment spindle and may have to be taken into account.

Also, the spindle strength is assumed to be  $\geq 500 \text{ N/mm}^2$ .

The details given on strength are non-binding guide values without any liability. In general, they do not constitute a warranty of quality.

The user must determine from case to case if a product is suitable for the intended purpose or use. Environmental factors may influence the stated values.

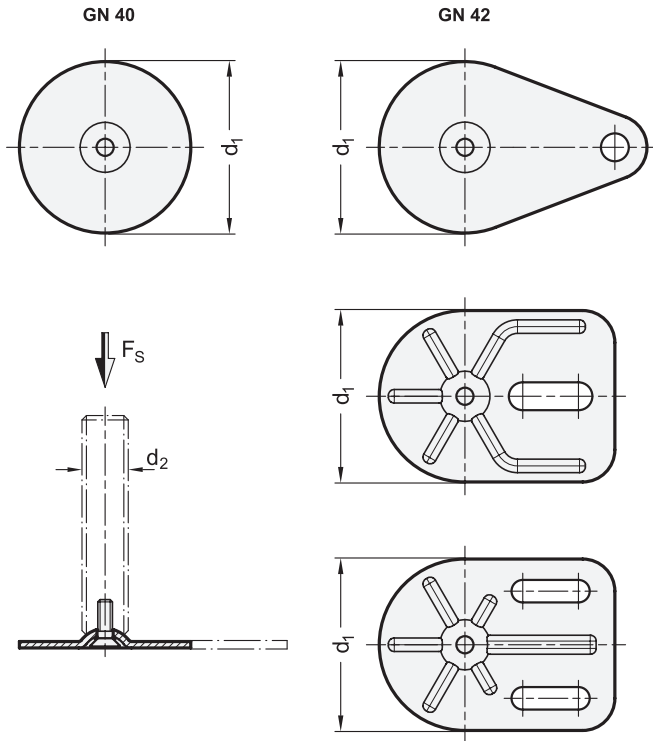

$d_1$			$d_2$	Static load $F_s$ in kN Versions of threaded stem		
GN 40	GN 42 drop shape	GN 42 rectangular shape		S / SK	U / UK	X
40	-	-	M 8	7	-	7
40	-	-	M 10	7	-	7
40	-	-	M 12	7	-	7
40	-	-	M 16	-	7	7
50	50	-	M 8	8	-	8
50	50	-	M 10	8	-	8
50	50	-	M 12	8	-	8
50	50	-	M 16	-	8	8
60	60	-	M 8	8	-	8
60	60	-	M 10	10	-	10
60	60	-	M 12	10	-	10
60	60	-	M 16	-	10	10
80	80	80	M 8	8	-	8
80	80	80	M 10	10	-	10
80	80	80	M 12	12	-	12
80	80	80	M 16	-	12	12
80	80	80	M 20	-	16	16
80	80	80	M 24	-	16	-