

Electrical specifications

Max. switching voltage / max. switched current:	250 V AC / 10 A 48 V DC / 5 A
Connector plug:	DIN EN 175301-803 Type C
Protection class:	IP 65
Cable gland:	PG 7, for cable-Ø from 6 to 7 mm
Max. cable cross-section:	2 x 1,5 mm ²

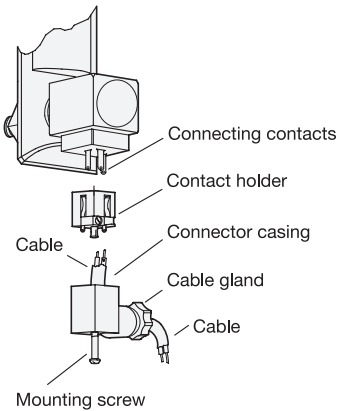
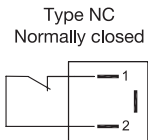
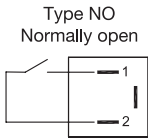

Assembly sequence for cable connection

1. Loosen the mounting screw and pull off the connector plug.
2. Push the contact holder out off the connector casing.
3. Loosen the cable gland, feed the cable through the connector casing and connect to the contact holder.
4. Push the contact holder back into the connector casing and tighten the cable gland for strain relief grip / seal.
5. Push the connector plug over the contacts of the oil level indicator and secure with mounting screw.

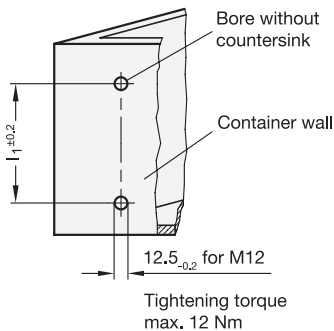

Assembly instruction

Two 12,5 Ø bore holes in the container wall are sufficient to mount the oil level indicator GN 650.6 with nuts.

The oil level indicator can also be mounted directly, i.e. without nuts, if the container wall has two M12 threads.