

2

l_1	d_1	d_2	h_1	h_2	l_2	l_3	l_4	l_5	l_6	l_7	l_8	l_9	l_{10}	m_1	m_2	m_3	m_4	m_5	r	s	x	y
75	6,5	4	60	30	44,5	30	51	99	93,3	24	80,4	41,7	69,3	61	8	40	46	28	73	7	36	28

Specification

1

3

- Aluminum **AL**
Anodized, natural color **EL**
- Hinge pins / Washers
Stainless steel 304
- Friction bearing
Plastic
- Self lubricated
- Temperature resistant -40 °C to 90 °C
- *Stainless Steel Characteristics* → Page 2166
- RoHS

On request

- Other finishes / colors
- Other fastening flanges
- Other opening angles
- Other max. wall thicknesses
- Other lifting motion

Information

The multiple-joint hinge GN 7243 is installed on the inside of doors, flaps and hatches to save space and ensure protection against vandalism. The hinge has a maximum opening angle of 120°, allowing for easy accessibility and making them suitable for use with medium-thick doors.

Use of this hinge type leaves housing exteriors free of attachments that do not match the design or that should be avoided entirely in the interests of fast and easy cleaning.

Multiple-joint hinges are generally used in pairs. For higher loads, e.g. from large doors, these can be supplemented with additional hinges. Four reinforced washers are supplied, which can be used with fastening screws of thread size M6.

see also...

- *Spacer Plates GN 7247.2* → Page 1366
- *Plates GN 7247.4 (with Tapped Holes)* → Page 1367
- *Plates GN 7247.6 (with Threaded Studs)* → Page 1368

How to order

GN 7243-AL-75-EL

1	Material
2	l_1
3	Finish / Color

Installation position - pivot characteristics

The multiple-joint hinges can be installed to the housing with the slots on the fastening flanges either parallel or perpendicular to the hinge axis. This results in the two pivot characteristics depicted.

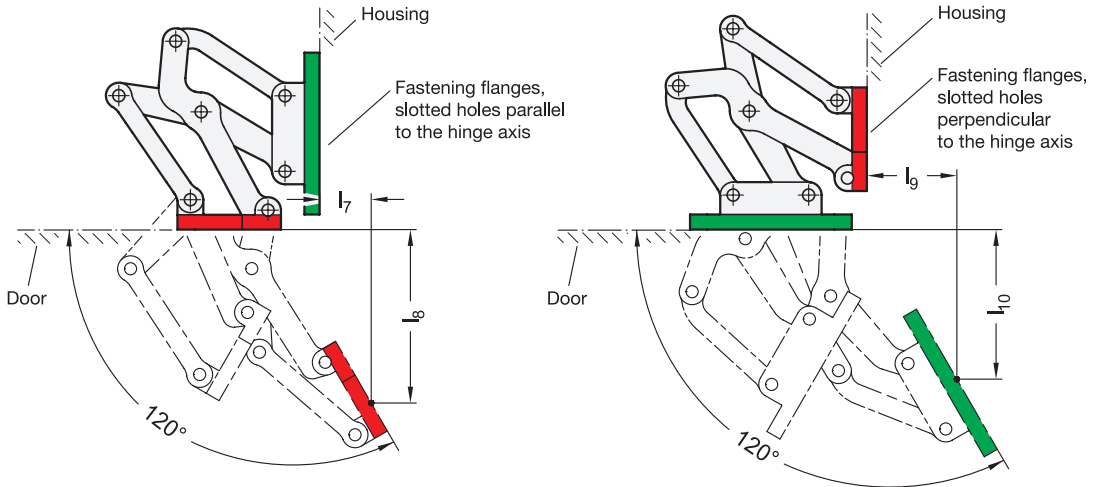

Examples of use

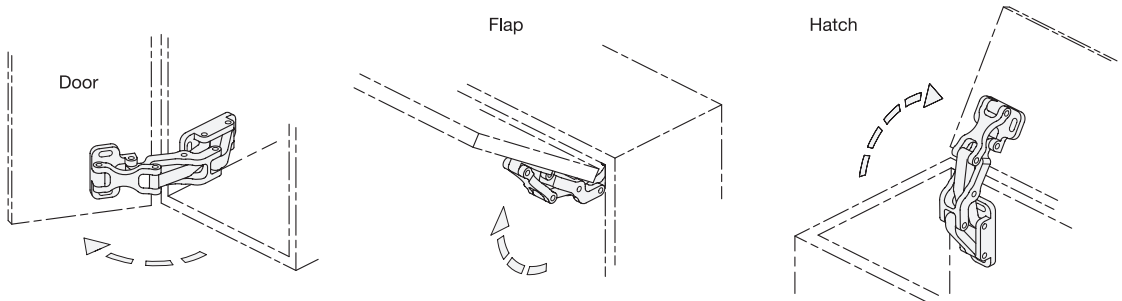

Adjustment and fastening options

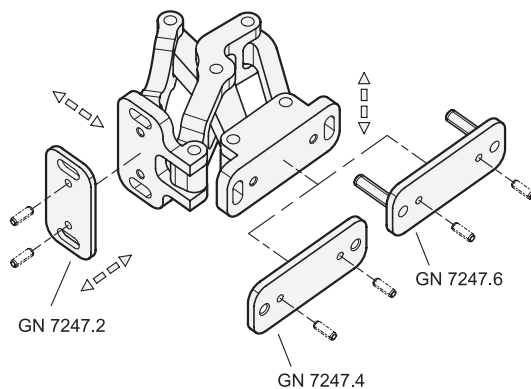

The multiple-joint hinges can be adjusted in three planes during installation. For example, this allows adjustment for tolerances or establishing of required compressive forces for seals. Two planes can be adjusted via parallel or perpendicular slots in the fastening flanges. In the third plane, position corrections can be made using the spacer plates GN 7247.2.

Plates with tapped holes GN 7247.4 as well as plates with threaded studs GN 7247.6 are also available for fastening the hinges. The latter can be welded on or inserted through the wall from the outside and fastened in place. The holes d_2 receive tensioning or positioning pins, making it easy to position the hinge. This also prevents unintended turning or slipping under load. The pins cannot be removed for subsequent adjustment.

Design variants

Doors, flaps and hatches can be inset, flush or mitered. The maximum wall thicknesses and bend sizes for sheet metal constructions given below arise from the respective installation type.

1. Fastening flange mounted to the housing with slots parallel to the hinge axis:

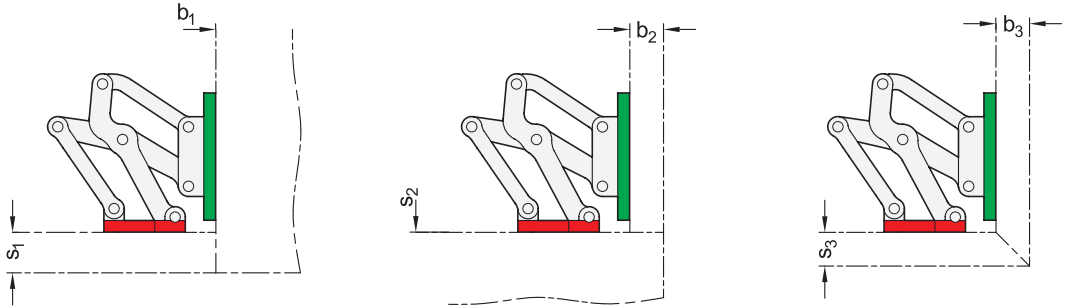

l_1	$s_1 \text{ max.}$	b_1	s_2	$b_2 \text{ max.}$	$s_3 \text{ max.}$	$b_3 \text{ max.}$
75	24	1 ... ∞	1 ... ∞	20	20	20

2. Fastening flange mounted to the housing with slots perpendicular to the hinge axis:

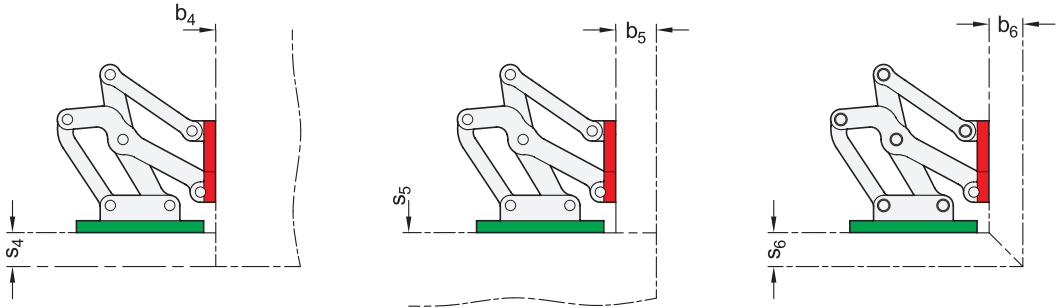

l_1	$s_4 \text{ max.}$	b_4	s_5	$b_5 \text{ max.}$	$s_6 \text{ max.}$	$b_6 \text{ max.}$
75	20	1 ... ∞	1 ... ∞	24	20	20

The design variants shown represent standard installation conditions. If the installation position of the hinge is changed or one of the two wall thickness dimensions is lower than s or b , the maximum achievable dimensions change independently of each other. This makes it possible in some cases to work with larger wall thickness dimensions than those specified with the same hinge size. A simple design check via CAD or a test setup is therefore recommended.



Example of an assembly

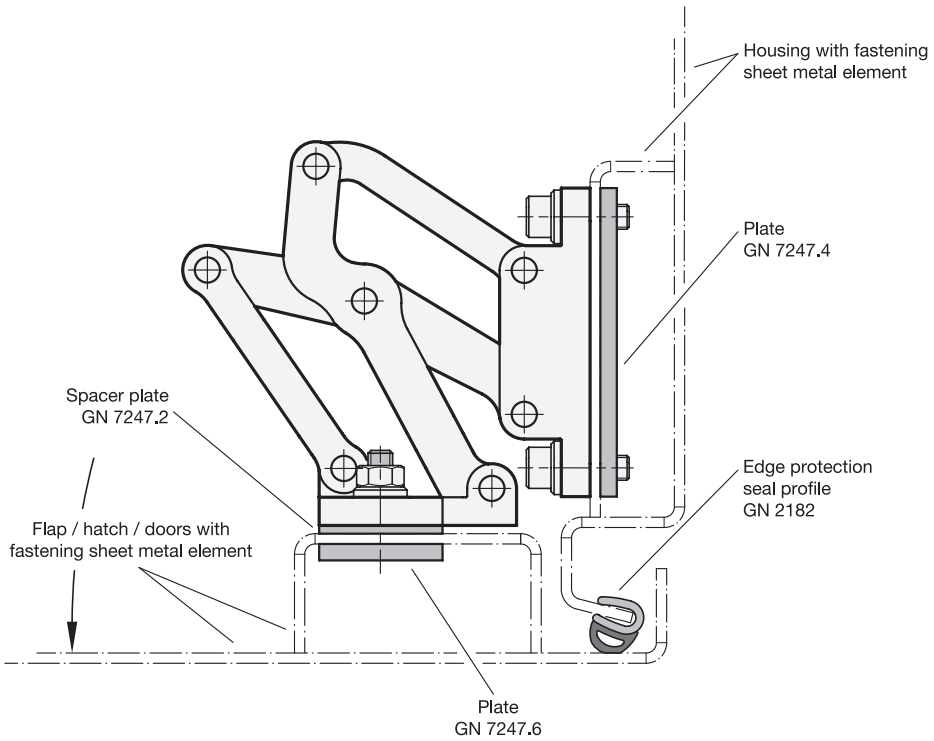

Load capacity

The maximum load of the multiple-joint hinge specified below applies to the standard use cases and serves for orientation in the case of deviating applications. The resulting forces lead to slight elastic deformation, which can be compensated for by means of the adjustment options, if necessary.

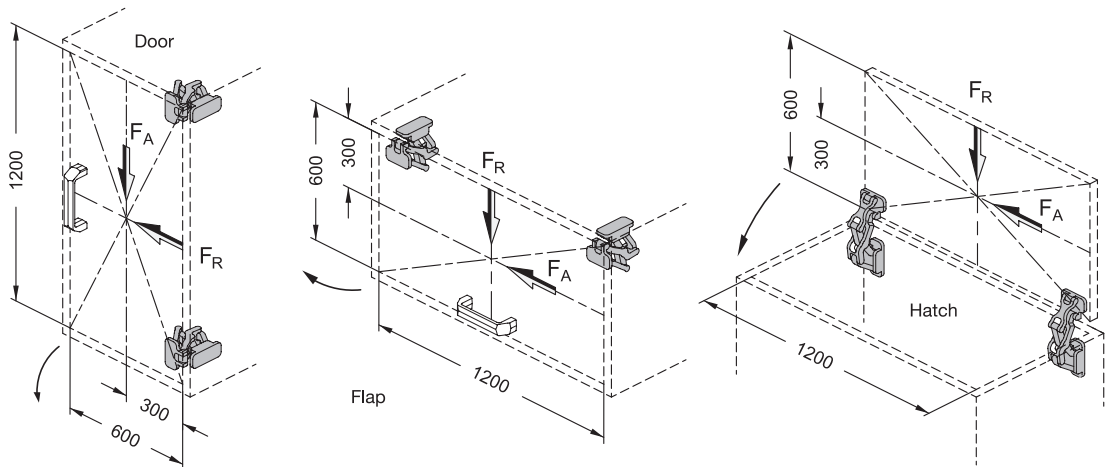

Max. load capacity per hinge pair in N

I_1	F_A (axial)	F_R (radial)
75	650	750