

Mounting examples

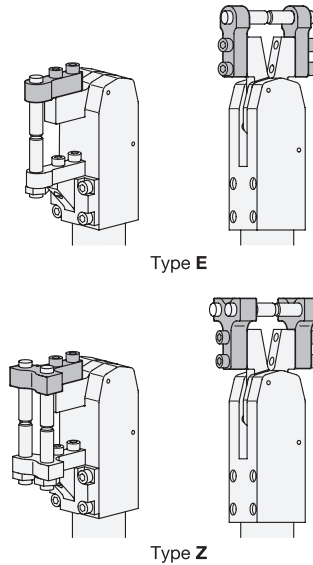

MISALI

3 Type

- E** For one clamping bolt
- Z** For two clamping bolts

1 2

For power clamps Size	1 b -0,2	2 d ₁	d ₂ ^{H8/h6}	d ₃	h	l ₁	l ₂	l ₃	l ₄	m ₁	m ₂	m ₃
20	10	M 8	7	M 5	10	37	13	30	19,5	12	14,5	17
32	12	M 10	9	M 6	12	53	17	40	29,5	18	20,9	23
40	16	M 12	11	M 8	14	63	20	50	34	22	23,5	30
50	18	M 12	13	M 10	16	73	20	60	34	27	28,5	40

Specification

- Steel C45
Chemically nickel plated **NC**
- Socket cap screws DIN 912,
centering guide bushings
Steel, blackened
- ISO Fundamental Tolerances → Page 2151
- RoHS

4

Information

Holders for clamping bolts GN 867 are suitable for use on clamping arms of the power clamps GN 864 / GN 865 / GN 866.

Holders for two clamping bolts (Type Z) are preferably used in such applications where absolutely rigid clamping of a sheet metal component is essential. For the same purpose ball point screws GN 605 with serrated ball pads are ideally suited.

Socket cap screws and centering guide bushings are included.

see also...

- Ball Point Screws GN 605 → Page 1052

How to order

GN867-12-M10-E-NC

- 1** b
- 2** d₁
- 3** Type
- 4** Finish