

Mounting examples

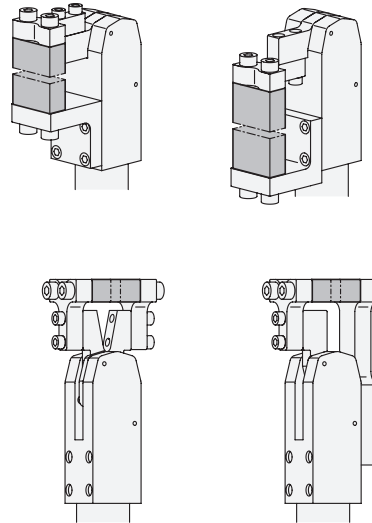

1

2

l_1	h	d_1	d_2 ^{H8} / _{h8}	l_2	$l_3 \pm 0,01$	t
30	25	50	M 6	9	13	8
40	35	70	M 8	11	17	12
50	45	80	M 10	13	20	15
60	50	85	M 10	13	20	15

Specification

- Steel C45 blackened
- ISO-Fundamental tolerances → Page 1480
- RoHS

Accessory

- Centering guide bushings GN 870 → Page 610

Information

Clamping jaws GN 872 are designed to be modified by the user into individual clamping designs, such as prisms and radii. They are also suitable for welding.

The fastening thread and centering bores are adapted to the dimensions of the clamping arms and static holders to enable quick and easy assembly.

Centering guide bushings GN 870 are **not** included.

How to order

GN 872-50-80

1

l_1

2

h