

Information

Telescopic slides can be delivered with a number of component options. Some are available for one of the two stop positions and in combination, and they are defined by the „type“ in the article number.

The following overview shows examples of possible characteristics of the various types and component features. The components used and the employed mechanisms are adapted to match the available installation space, cross section, and structure of the selected slides and have accordingly different designs depending on slide variant. Functionality is comparable, however, and sometimes even identical.

Rubber stops

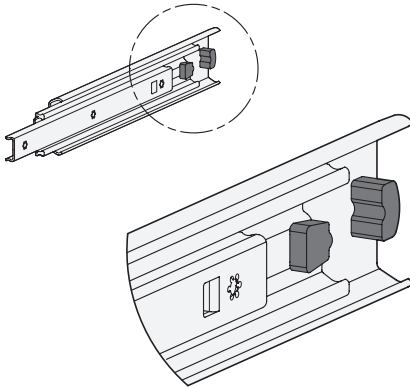

The rubber stops used in almost all slide variants dampen the impact of the slide in the respective end position. This feature minimizes noise development and increases the lifespan. Attached to the slides in a partially concealed, partially visible manner, the stops meet each of the requirements in regard to shape, material, and hardness.

If larger static or dynamic loads occur in the direction of extension, they should be absorbed by external stop elements.

Locking devices

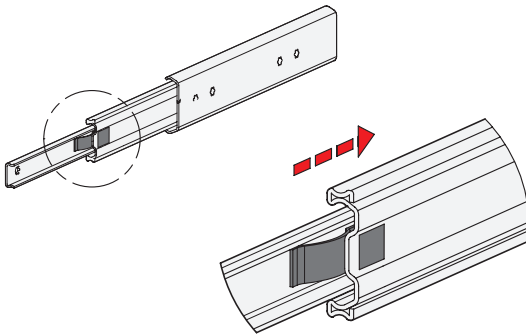

The locking function is noticeable by a slight resistance of the slides in the end positions, which has to be overcome on opening and closing. The locking device in the back stop position is usually integrated into the rubber stop function, making additional components unnecessary.

The locking device is frictionally engaged and, therefore, does not act as a positive locking latch.

Latches

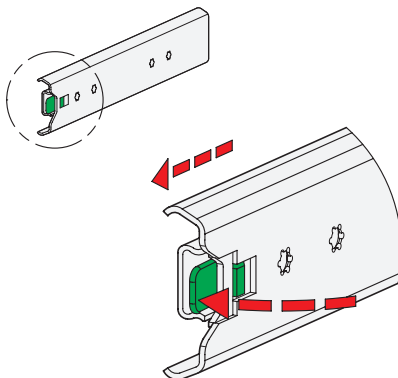

Unlike locking devices, a latch secures the slides in the stop positions in a frictionally engaged way. Telescopic slides with latches are used when the slides need to be protected against independent extension or retraction, for example, due to a tilted position.

A mechanism found within the inner slide latches automatically spring-loaded by moving over a ramp on reaching the respective stop position. Pressing the release lever releases the latch, allowing the slide to move again.

If larger loads occur in the direction of extension in the latched position, they should be absorbed by external latch elements.

Self-retracting mechanism

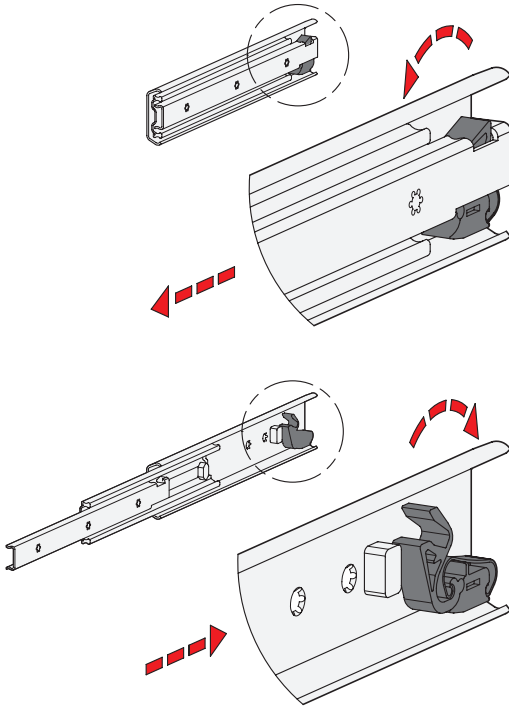

Telescopic slides can have an integrated self-retracting mechanism, which improves considerably the ease of use when closing the extensions.

In the version shown in the example, the slides are retracted and held in the back end position automatically by means of a retraction mechanism on the last 22 mm of stroke with a force of approximately 30 newtons for each slide pair. This force has to be overcome accordingly on opening the extension.

This variant is also designed in such a way that mechanism uncouples and will not be damaged when the extension is opened or closed in a jerky manner or too quickly. On the following stroke, the self-retracting mechanism clicks back into place automatically, ensuring that the function remains intact.

Self-retracting mechanism, dampened

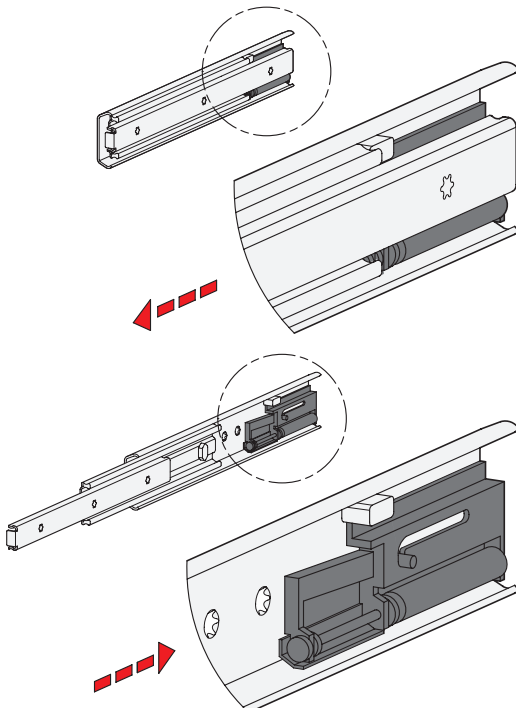

Dampened self-retracting mechanisms are also called “soft-close” and are divided into two main functions. They offer the best possible ease of use on closing the extension.

In the example shown, the self-retracting mechanism takes over the automatic retraction of the slides on the last 40 mm of stroke in the back stop position, where the slides are then held in place. The retraction force is about 35 newtons per slide pair. Also the dampening mechanism slows down to a considerably reduced speed the closing movement on the said stroke, while achieving an extremely gentle and smooth closing movement. This retraction force has to be overcome accordingly on opening the extension.

When dampened self-retracting mechanisms are used, the specified load values and stroke speeds may not be exceeded on reaching the retraction mechanism.

Detach function

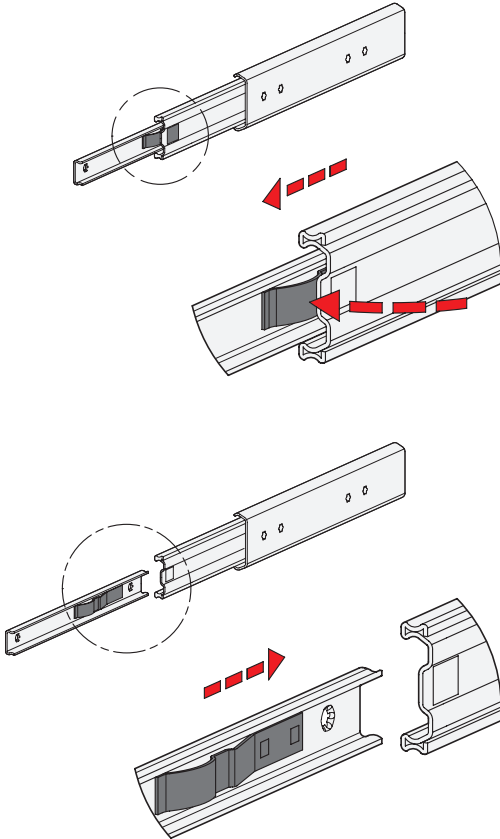

Telescopic slides with a detach function can be completely separated from one another in the area of the middle and inner slide. This feature not only facilitates mounting. It also allows the extension to be quickly removed, for example, when maintenance work is performed on the components located behind.

In the example shown, the telescopic slide can be quickly and easily detached in the extracted position through activation of a flat spring, allowing the inner slide to be removed from the front.

For reattaching the slides, the ball cages need to be moved basically to the front end position. Then the inner slide is inserted to the back end stop where it locks back into place automatically.

The protected arrangement of the various release mechanisms prevents accidental detachment of the slide.

Support and mounting brackets

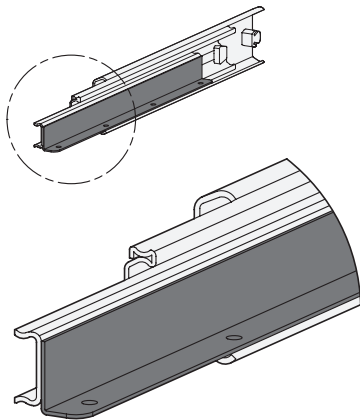

Support brackets on the inner slide are available on request for some slide variants, even in small quantities. The support bracket is used for simple fastening, for example, of a drawer, if side mounting is not possible. Fastening occurs by means of through-holes that are arranged at a right angle in the bracket.

The fastening screws secure only the position of the drawer in this case. Additional reinforcement of the slides themselves, as with side mounting, is not possible. The drawers should therefore be designed as rigidly as possible so that the perpendicular load does not introduce any unnecessary tension through the support bracket into the slides.