

Spoked Handwheel for

- Linear Actuator $\varnothing 50 / \varnothing 50$
 - Double Tube Linear Actuator $\varnothing 50$
- GN 924.50-140-K12-R

Specification

see GN 924 → Page 238

3.1

3.2

3.3

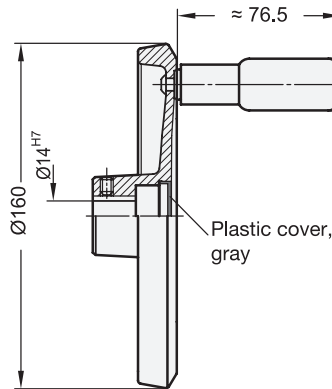
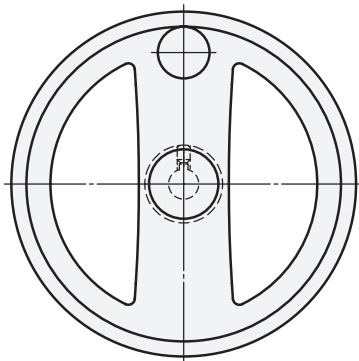

Spoked Handwheel for

- Linear Actuator $\varnothing 60$
 - Double Tube Linear Actuator $\varnothing 60$
- GN 924.60-160-K14-R

Specification

see GN 924 → Page 238

3.4

3.5

3.6

3.7

3.8

3.9

