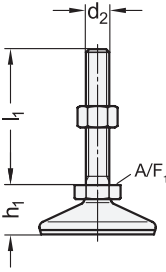
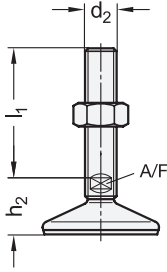
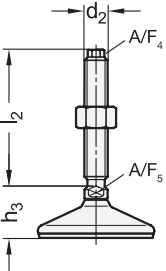
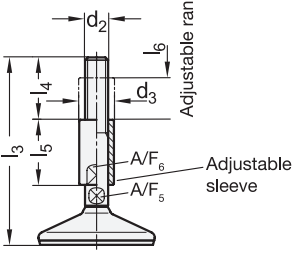

Versions of threaded stud

<p style="text-align: center;">External hex at the bottom</p>  <p style="text-align: right;"> 5 S Without nut SK With nut (M 8...M 12) </p>	<p style="text-align: center;">Wrench flat at the bottom</p>  <p style="text-align: right;"> 5 T Without nut TK With nut (M 16...M 30) </p>
<p style="text-align: center;">External hex at the top, wrench flat at the bottom</p>  <p style="text-align: right;"> 5 V Without nut VK With nut (M 16...M 24) </p>	<p style="text-align: center;">Covered thread, wrench flat at the bottom</p>  <p style="text-align: right;"> 5 W With adjustable sleeve (M 16...M 24) </p>

d ₁	d ₂			d ₃	h ₁	h ₂	h ₃	l ₄	l ₅	l ₆	s	A/F ₁	A/F ₂	A/F ₄	A/F ₅	A/F ₆	w in °
60	M 8	M 10	M 12	-	31	-	-	-	-	-	2	17	-	-	-	-	32
60	M 16	-	-	24	-	37	33	45	45	29	2	-	12	10	12	20	32
80	M 8	M 10	M 12	-	33	-	-	-	-	-	2	17	-	-	-	-	26
80	M 16	-	-	24	-	39	35	45	45	29	2	-	12	10	12	20	26
80	M 20	-	-	30	-	39	36	56	56	36	2	-	15	13	16	24	26
80	M 24	-	-	35	-	41	38	67	67	42	2	-	19	17	20	30	26
100	M 8	M 10	M 12	-	35	-	-	-	-	-	2	17	-	-	-	-	22
100	M 16	-	-	24	-	41	37	45	45	29	2	-	12	10	12	20	22
100	M 20	-	-	30	-	41	38	56	56	36	2	-	15	13	16	24	22
100	M 24	-	-	35	-	43	40	67	67	42	2	-	19	17	20	30	22
120	M 20	-	-	-	-	43	-	-	-	-	2	-	15	-	-	-	20
120	M 24	-	-	-	-	46	-	-	-	-	2	-	19	-	-	-	20
120	M 30	-	-	-	-	50	-	-	-	-	2	-	24	-	-	-	20

see also...	Page
GN 18 Leveling Feet (Stainless Steel Quality Class 4)	QVX
GN 19 Leveling Feet (Hygienic Design)	QVX
GN 31 Leveling Feet (with Rubber Pad)	QVX
GN 33 Leveling Feet (with Mounting Flange)	QVX
GN 41 Leveling Feet (with / without Rubber Pad)	QVX

Technical Information	
Load Rating of Leveling Feet GN 17 / GN 18	QVX
Plastic Characteristics	QVX
Stainless Steel Characteristics	QVX