



**elesa**  
Original design RE.C6-C.

**2 Bearing type**

**G** Friction bearing

**3 Type (bracket)**

**B** Rigid bracket

**L** Swivel bracket with mounting plate

**LF** Swivel bracket with mounting plate, with total lock brake

**R** Swivel bracket with center hole

**RF** Swivel bracket with center hole, with total lock brake

**G** Swivel bracket with threaded stud

**GF** Swivel bracket with threaded stud, with total lock brake

**4 Coding**

**L** Light version

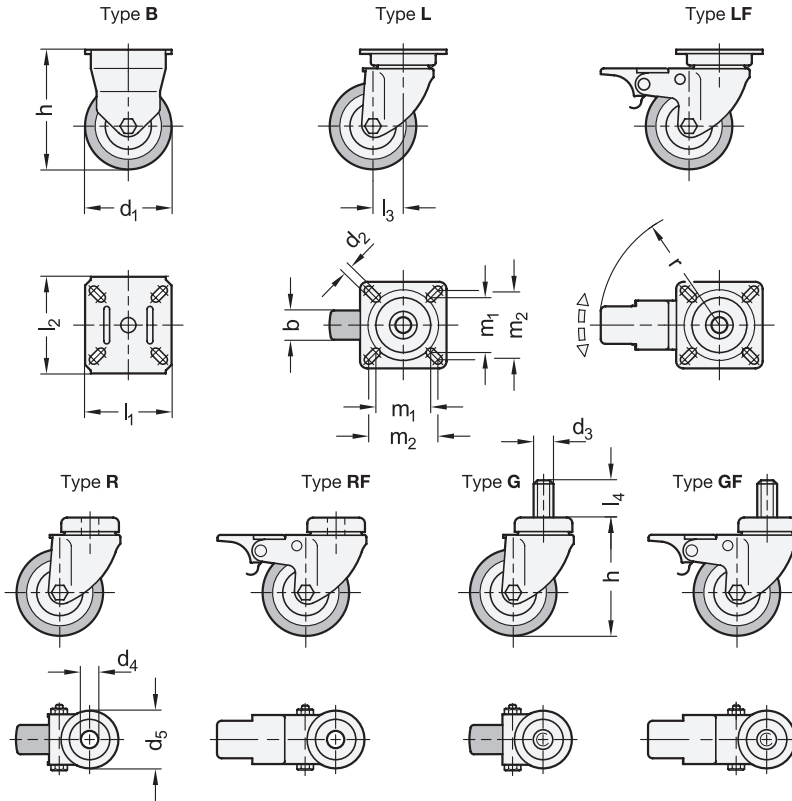

d <sub>1</sub> Wheel Ø	b	d <sub>2</sub>	d <sub>3</sub>	d <sub>4</sub>	d <sub>5</sub>	h	l <sub>1</sub>	l <sub>2</sub>		l <sub>3</sub>	l <sub>4</sub>	m <sub>1</sub>		m <sub>2</sub>		r	Max. dynamic load capacity in N	
								Type B	Type L / LF			Type B	Type L / LF	Type B	Type L / LF			
40	18	5	M 10	10	35	59	48	42	48	42	24	20	27	30	33	33	78	400
50	18	6	M 10	10	35	66	55	55	55	55	24	20	38,5	38,5	44	44	78	550
60	24	6	M 12	12	42	82	60	60	67	60	21	25	38,5	38,5	47	48	83	700

**Specification**

**Wheel tread**

Thermoplastic polyurethane (TPU)

- Injection molded
- Red
- Hardness 55 Shore D

**Wheel core**

Plastic, polyamide (PA)

**Bracket**

Steel sheet metal, zinc plated

**ST**

**Swivel head bracket**

Dual grease-lubricated ball bearing

**Operating temperature** -5 °C to +40 °C

RoHS

**Technical Information**

**Page**

Usage Conditions of Wheels and Casters QVX

Technical Information for Wheels and Casters QVX

Plastic Characteristics QVX

Light duty casters GN 22880 are used in industrial and public indoor areas for moving light materials and equipment, for example.

The wheel tread offers low rolling resistance and high elasticity as well as good wear and tearing resistance. It is good at overcoming obstacles.

see also...

**GN 22880** Wheels (without Bracket) **Page** QVX

**GN 22880** Light Duty Casters (Double Wheel Version) QVX

**GN 22870** Light Duty Casters (Wheel Tread Rubber, Wheel Core Polypropylene) QVX

**GN 22882** Medium Duty Casters (Wheel Tread Polyurethane, Orange) QVX

**GN 22884** Medium Duty Casters (Wheel Tread Polyurethane, Blue) QVX

**How to order**

1	d <sub>1</sub>
2	Bearing type
3	Type (bracket)
4	Coding
5	Material (bracket)

**GN 22880-40-G-B-L-ST**