

Coding P

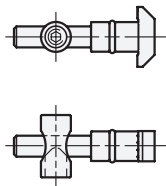

Coding R

**Assembly / profile machining**

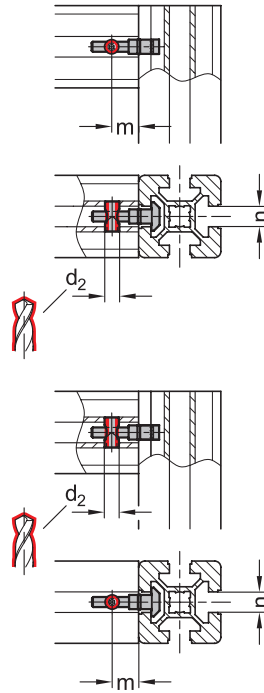

**2 Type**  
S Symmetrical mounting stud

**3 Coding**  
P Parallel T-nut  
R Right-angle T-nut

**1**

**5**

n	Bundle Pieces	b	d <sub>1</sub>	d <sub>2</sub>	l <sub>1</sub> ≈	l <sub>2</sub>	l <sub>3</sub>	m	A/F	Tightening torque in Nm
10	4	10	6,8	10	46	10,3	20	22,5	3	6

**Specification**

- Steel, zinc plated, blue passivated
- RoHS

**4**

**Information**

Quick release connectors GN 25b fasten aluminum profiles together at right angles. Only one profile has to be machined.

The connection can be freely positioned and slid along the slot. The internal hex used for clamping is situated for especially easy access.

If panels are used, they must be suitably pocketed, depending on the type, coding and installation orientation.

Quick release connectors of type S are used when the slot is to be closed by a cover profile.

Quick release connectors are supplied in bundles. The table shows the quantity included in each bundle.

see also...

- Aluminum Profiles GN 10b (Profile Type Light) → Page QVX
- Aluminum Profiles GN 10b (Profile Type Heavy) → Page QVX

**How to order**

<b>1</b>	n
<b>2</b>	Type
<b>3</b>	Coding
<b>4</b>	Material / Finish
<b>5</b>	Bundle

**GN 25b-10-S-R-SZ-4**



## Assembly Instructions / Profile Machining

Type S

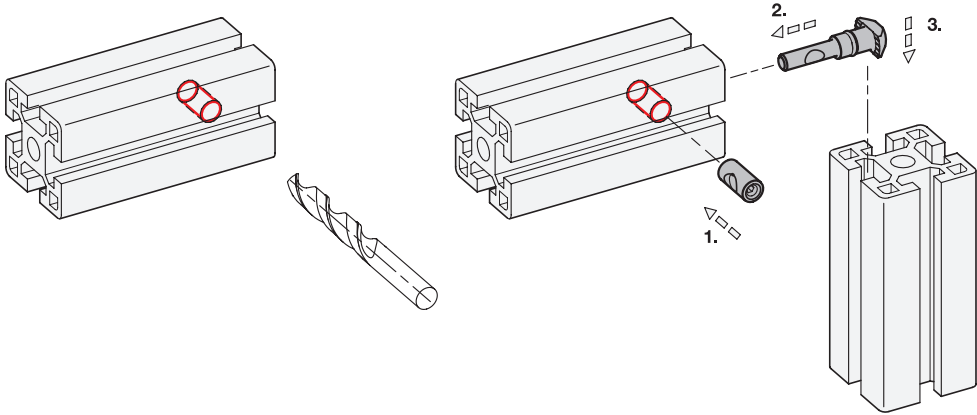

Type A

