

1.1
1.2
1.3
1.4
2.1
2.2
2.3
2.4

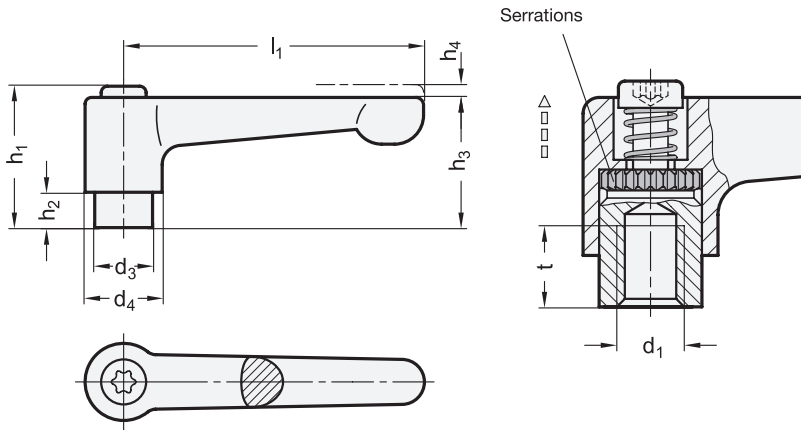

l ₁	d ₁ Thread			d ₃	d ₄	h ₁	h ₂	h ₃	h ₄ Stroke	t min.
	M 3	M 4	M 5							
22	M 3	M 4	M 5	8	10,5	18,5	2	16,5	3	5
30	M 4	M 5	M 6	10	13	24,5	4	22	3,5	9
45	M 4	M 5	M 6	10	13	24,5	4	22	3,5	9
63	M 6	M 8	-	13,5	17,5	31	6,5	28,5	4	11
78	M 8	M 10	-	16	21	36	8	34	4	14

Specification

Handle

Zinc die casting
Powder coated

- Black, RAL 9005, textured finish
- Orange, RAL 2004, textured finish
- Red, RAL 3000, textured finish
- Silver, RAL 9006, textured finish

- SW
- OS
- RS
- SR

Bushing and retaining screw

Steel
Zinc plated, blue passivated

RoHS

Adjustable hand levers GN 302.2 have a straight lever, not inclined, being parallel to the clamping space.

Adjustable hand levers are ideal whenever parts have to be clamped in a confined space or in a particular lever position. The centre insert is connected to the lever via serrations which can easily be disengaged.

Pulling the lever, disengages the serrations and allowing it to be swivelled to the ideal clamping position. On releasing the lever the serrations automatically re-engage.

see also...

	Page
GN 302 Flat Adjustable Hand Levers (Bushing Steel Blackened)	QVX
GN 302.1 Flat Adjustable Hand Levers (Bushing Stainless Steel)	QVX
GN 300.2 Adjustable Hand Levers (Bushing Steel Zinc Plated)	QVX

How to order

GN 302.2-63-M6-SW

1	l ₁
2	d ₁
3	Color

