



1.1

1.2

1.3

1.4

### Assembly examples

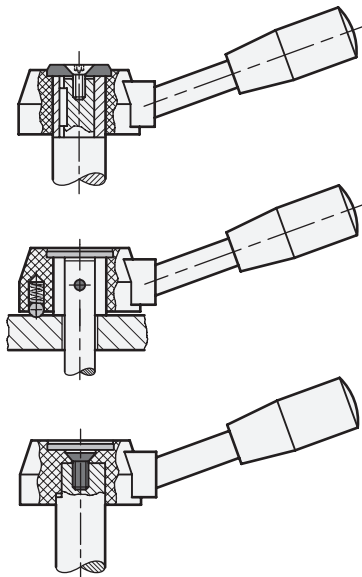

Gear lever GN 512 attached with keyway / parallel key, using GN 184 countersunk washer → [Page 1090](#).

Gear lever GN 512 with ball and spring snap mechanism for indexing the gearing angle, attached with cross pin. The cross pin is to be attached at an angle of 45° to the shaft axis. These parts are not included in the delivery and must be ordered separately.

Gear lever GN 512 in special design, without steel bushing with injected blind hole and driver surface. This model is a very reasonably priced solution.

2.1

2.2

2.3

2.4

