

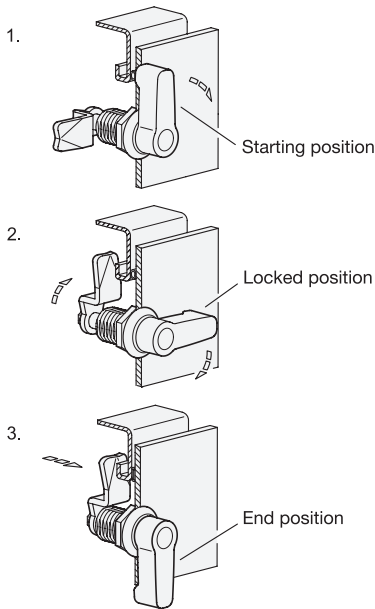

Construction and assembly instructions



1. Latch in starting position.
2. The first 90° turn of the operating element or key moves the latch arm into the locking position.
3. The second 90° turn initiates a 6 mm linear movement of the latch arm. This pulls the door against the frame and the seal, creating a vibration-proof latch in the end position.

For installation, set a hole in the door, cover or hatch as shown in the outline drawing.

When installed, the rotary clamping latches are inserted through the hole from the front. The hex nut can then be pushed over the latch from the back and bolted in place.

The required installation bore in the door leaf, is usually generated by punching or laser machining in series production.

The installation bore diameter can also be created by drilling or milling as shown in the outline drawings.

For small series and steel sheets below 2 mm thickness, the sheet metal punch GN 123 (Page XYZ) are the tool of choice.

Load of rotary clamping latches

Max. torque	4,5 Nm
Max. axial force / max. static load	340 N

Hole distance

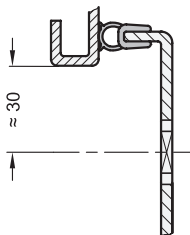

Installation hole for punching or laser machining

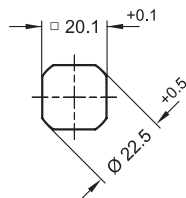

Installation hole for drilling or milling

