

Mounting example

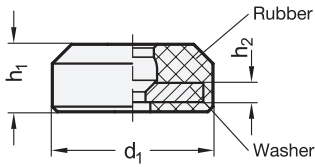
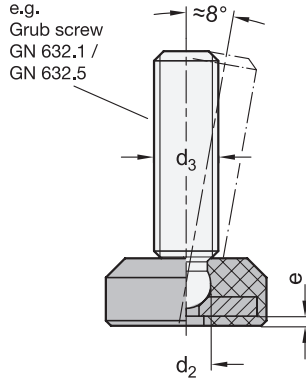

¹ d ₁	² d ₂	d ₃	e ≈	h ₁	h ₂
14	4,5	M 6	1	7,5	2
19	6,1	M 8	1,5	10	3
25	7,8	M 10	1,5	11	3
32	9,4	M 12	2	13	4

Specification

Acrylonitrile butadiene rubber (NBR)

- 85 ±5 Shore A ³ **85**
- Operating temperature up to 120 °C
- Black, matte finish
- Washer

● **SW**

RoHS

On request

Other Shore hardnesses

Accessory

GN 632.1 Grub Screws (Steel)	QVX
GN 632.5 Grub Screws (Stainless Steel)	QVX
GN 306 Adjustable Hand Levers	QVX
GN 6336.11 Star Knobs	QVX
GN 7336.5 Knurled Screws	QVX
GN 421.11 Knurled Screws	QVX
GN 903 Clamping Screws	QVX
GN 933.5 Hex Head Screws	QVX

Thrust pads GN 631.2 are used for clamping and pressing when surfaces must be protected against damage. They also counteract slipping, dampen shocks and reduce noise. The disk is encased in vulcanized rubber to ensure high load capacity and dimensional stability.

Depending on the application, various standard parts with ball thrust point are available as accessories.

Together with the thrust pad, the ball thrust point forms a ball joint that adapts to clamping surfaces that are uneven or not perpendicular to the screw axis. It also prevents the clamping surface from rotating when the thrust pad is in contact to the clamping surface.

The ball thrust point snaps securely into the thrust pad and can be removed again if needed.

see also...

	Page
GN 638 Ball Jointed Leveling Feet	QVX
GN 631 Thrust Pads (Plastic)	QVX
GN 631.5 Thrust Pads (Stainless Steel)	QVX

Technical Information

Information of Static Load	QVX
Plastic Characteristics	QVX
Stainless Steel Characteristics	QVX

How to order

¹ d ₁
² d ₂
³ Hardness
⁴ Color

GN 631.2-32-9,4-85-SW