

ROSTFREI  
Inox  
Stainless  
Steel

- 4 Thread direction of spindle**
- RH** Right hand thread
  - RHK** Right hand thread with spindle clamping via shaft collar and hand lever
  - LH** Left hand thread
  - LHK** Left hand thread with spindle clamping via shaft collar and hand lever

**1** **3**

d <sub>1</sub>	l <sub>1</sub> Stroke max.	b	d <sub>2</sub>	d <sub>3</sub>	d <sub>4</sub>	d <sub>5</sub>	d <sub>6</sub>	For screw DIN 912	d <sub>7</sub>	d <sub>8</sub>	For screw DIN 912	d <sub>9</sub>	d <sub>10</sub>	For screw DIN 912
25	1500	50	8	M 6	M 6	6,1	10,5	M 6	5,5	10	M 5	6,6	11	M 6
40	2500	60	12	M 8	M 8	8,4	13,5	M 8	6,6	11	M 6	8,6	13,5	M 8

d <sub>1</sub>	h <sub>1</sub>	h <sub>2</sub>	h <sub>3</sub>	h <sub>4</sub>	l <sub>2</sub> Total length	l <sub>3</sub>	l <sub>4</sub>	m <sub>1</sub>	m <sub>2</sub>	m <sub>3</sub>	m <sub>4</sub>
25	52	64	2	27	2xb+l <sub>1</sub> +l <sub>4</sub>	130	130	b+l <sub>4</sub> +l <sub>1</sub>	114	97	30
40	60	75	3	31,5	2xb+l <sub>1</sub> +l <sub>4</sub>	180	180	b+l <sub>4</sub> +l <sub>1</sub>	160	138	39

d <sub>1</sub>	m <sub>5</sub>	m <sub>6</sub>	m <sub>7</sub>	m <sub>8</sub>	m <sub>9</sub>	m <sub>10</sub>	m <sub>11</sub>	m <sub>12</sub>	m <sub>13</sub>	Parallel key DIN 6885
25	35	30	42	9,5	12	114	80	80	114	A2x2x12
40	38	39	52	12,5	12	160	120	120	160	A4x4x12

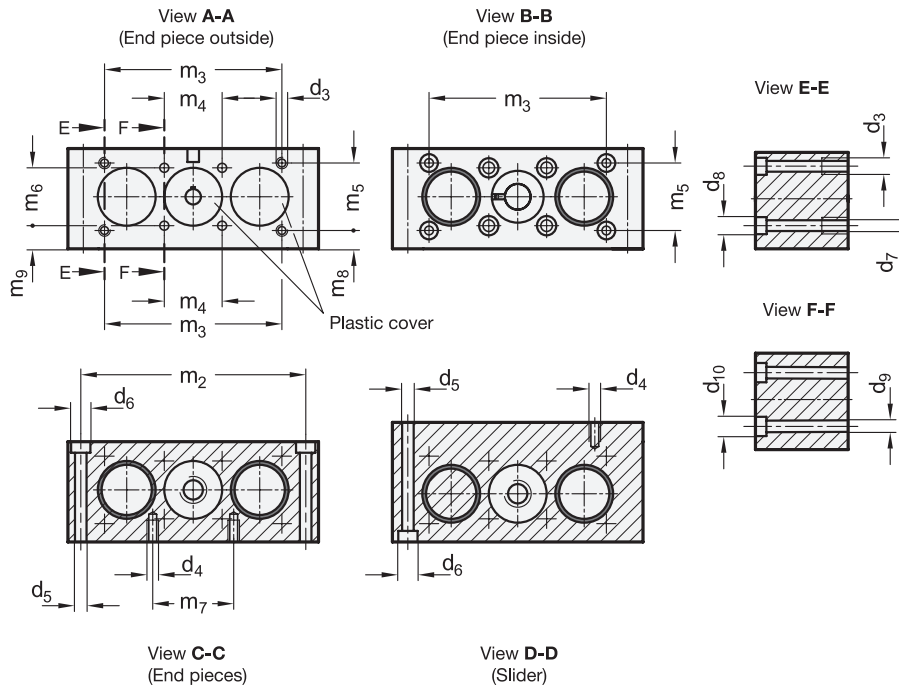

## Specification

- Double solid shaft roller guide
  - Steel CF53 ground, hard chrome plated **3ST**
  - Stainless steel, ground, inductively hardened **3NI**
- Ball screw drive, ball bearing
- End piece / slider
  - Aluminum
  - All surfaces machined, plain finish
- Positioning accuracy
  - $\pm 0.05 \text{ mm} / 300 \text{ mm stroke}$
- *Stainless Steel Characteristics*
  - *Main catalogue Page 2166*
- **RoHS**



## Information

The round guides of the precision double tube linear GN 6922 actuators are made of hard chrome plated steel or ground stainless steel solid shafts. The aluminum end pieces connect the solid shafts and form a precise linear guide together with the slider. A continuous recirculating ball screw is installed in the center. The linear movement of the double slider is driven by the ball screw nut affixed in the slider.

Precision double tube linear actuators have high torsional stiffness and can accept high weights and torques, since the load is introduced and distributed over a large surface area. Depending on the setup, either the component to be adjusted is attached to the slider or the slider itself is installed at the point of use, so that the entire linear actuator moves.

The overview shows a range of possible accessories that can be installed on the precision double tube linear actuator in the various configurations. The design and length of the journals vary depending on the accessories, which must be taken into consideration when selecting the linear actuator. The accessories are not included with the linear actuators and must be ordered separately. For this purpose, please refer to the design overview on page 68.

see also...

- *Precision Double Tube Linear Actuators GN 6920* → *Page 36*
- *Double Tube Linear Actuators GN 4920* → *Page 12*

5

$d_1$	Spindle pitch	Journal diameter $d_2$	Journal length			
	Ball groove thread		$l_5$	$l_6$	$l_7$	$l_8$
25	5	8	16	36	52	16 ... 67
40	5	12	17	42	59	17 ... 74

Overview accessories

Handwheels <b>GN 9234</b> Page 69	Position Indicators <b>GN 9034</b> Electronic counter Page 72

Version - Journal 1

<p><b>B</b> Journal for handwheel</p>	<p><b>D</b> Journal for position indicator and handwheel</p>
Journal length $l_5$	Journal length $l_7$
<p><b>Gxx</b> Individual length with parallel key (for xx value from table column <math>l_8</math>)</p>	<p><b>Hxx</b> Individual length without parallel key (for xx value from table column <math>l_8</math>)</p>
Journal length $l_8$	Journal length $l_8$

Version - Journal 2

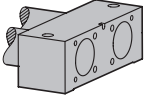
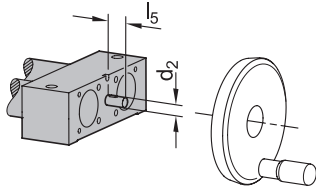
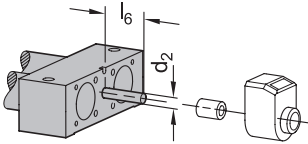
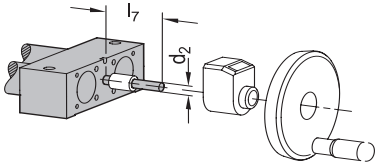
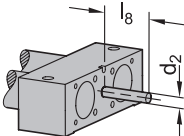
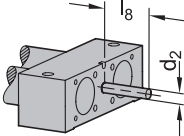
 <p><b>A</b> Without journal</p>	 <p><b>B</b> Journal for handwheel</p>
 <p><b>C</b> Journal for position indicator</p>	 <p><b>D</b> Journal for position indicator and handwheel</p>
 <p><b>Gxx</b> Individual length with parallel key (for xx value from table column I<sub>8</sub>)</p>	 <p><b>Hxx</b> Individual length without parallel key (for xx value from table column I<sub>8</sub>)</p>
<p>Cover cap</p>	<p>Journal length I<sub>5</sub></p>
<p>Journal length I<sub>6</sub></p>	<p>Journal length I<sub>7</sub></p>
<p>Journal length I<sub>8</sub></p>	<p>Journal length I<sub>8</sub></p>

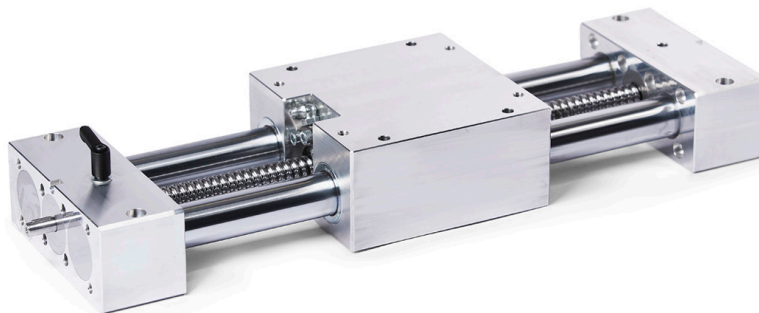

How to order

Standard section

Supplemental section

1
2
3
4
5
6
7  
**GN 6922-40-3ST-1000-RH-5-D-A**

<p><b>1</b> Outer diameter d<sub>1</sub></p>	<p><b>4</b> Thread direction of spindle</p>	<p><b>7</b> Version journal 2</p>
<p><b>2</b> Material</p>	<p><b>5</b> Spindle pitch</p>	
<p><b>3</b> Stroke I<sub>1</sub></p>	<p><b>6</b> Version journal 1</p>	