

3 Type

A Flat locating surface

1 d_1	2 d_2	d_3	d_4	h	Length l	s
28	M 4	26	24	10	5	24
42	M 5	40	38	11	5	38

Specification

- Stainless steel AISI 318LN
Matte finish ($Ra < 0.8 \mu m$) **MT**
- Sealing ring **H**
 - H-NBR
Temperature resistant $-25 \text{ }^\circ C$ to $+150 \text{ }^\circ C$
 - EPDM **E**
Temperature resistant $-40 \text{ }^\circ C$ to $+120 \text{ }^\circ C$
 - Blue
 - Hardness 85 ± 5 Shore A
 - FDA compliant
- Plastic Characteristics → Page QVX
- RoHS

Accessory

- Sealing Rings GN 7600 → Page QVX
- Nuts GN 1580 → Page QVX

On request

- With FKM sealing ring (fluoro-elastomer) **F**

Information

Holding disks GN 7080 are used as counterparts for retaining magnets when these are used in combination with non-magnetic materials or when the holding force needs to be increased due to thin material.

They are intended for use in hygiene areas. The sealed screw-on surface enables mounting without dead spaces; the impervious geometry in combination with the high quality finish prevents dirt from accumulating and facilitates cleaning.

The holding disks can also be used in particularly aggressive environments thanks to the material used.

see also...

- Product Family [Hygienic Design](#) → Page QVX
- Assembly Instructions GN 5080 / GN 5090 / GN 7080 / GN 7090 → Page QVX
- Retaining Magnets GN 5080 (with Threaded Stud, [Hygienic Design](#)) → Page QVX
- Retaining Magnets GN 5090 (with Internal Thread, [Hygienic Design](#)) → Page QVX
- Holding Disks GN 70 (Steel / Stainless Steel) → Page QVX

How to order

1	d_1
2	d_2
3	Type
4	Finish
5	Material (sealing ring)

GN 7080-28-M4-A-MT-E



Retaining magnet with holding disks

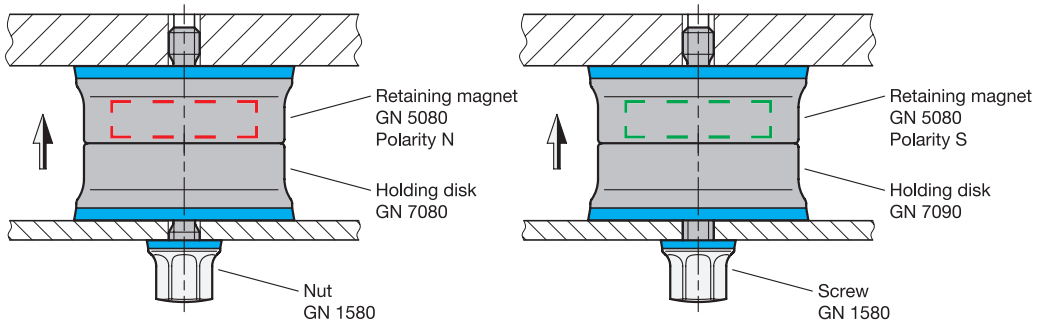

A normal holding force is achieved by combining retaining magnets with holding disks. Retaining magnets with north or south poles on the holding surface can be used equally.

Two retaining magnets with opposite polarity

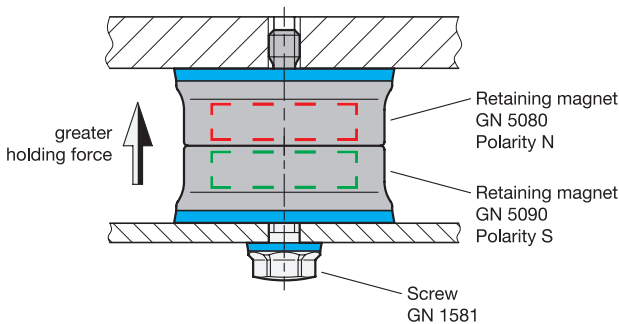

If two retaining magnets with opposite polarity are combined, an increased holding force is achieved.

Two retaining magnets with the same polarity

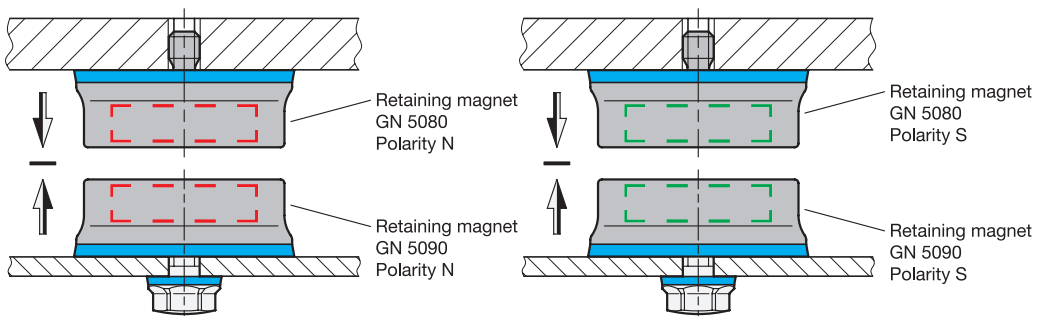

Combining two retaining magnets with the same polarity creates a repelling force.