

**Application example**

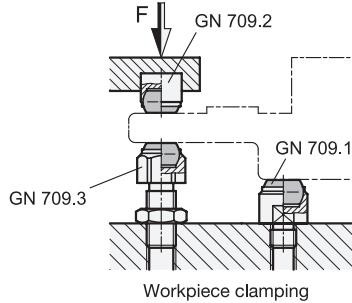

**3 Type**

- B** Smooth contact face
- R\*** Serrated contact face
- BR** Smooth contact face, with automatic return
- RR\*** Serrated contact face, with automatic return

1 2

A/F <sub>1</sub>	d <sub>1</sub>	d <sub>2</sub>	d <sub>3</sub> Ball-Ø	e	l <sub>1</sub>	l <sub>2</sub>	A/F <sub>2</sub>	Static load max. in kN
13	M 8	5,8	8,5	14,5	25	36,6	13	8
17	M 10	8,6	12	19	30	45,7	17	8
17	M 12	8,6	12	19	35	50,7	19	15
24	M 16	10,5	16	27	40	60,7	24	25
30	M 20	20	25	33	50	77,3	30	90
36	M 24	20	25	40	70	100	36	90
46	M 30x1,5	34,6	40	51	65	100	46	165

\*only available for GN 709.3

**Specification**

- **GN 709.3**  
Steel  
Tempered, phosphated
  - Ball steel
  - Hardened, plain
  - Spring element plastic (PUR) (Type BR / RR)
  - Hexagon nut ISO 4035 (DIN 439) Steel, blackened

- **GN 709.35**  
Stainless steel AISI 431  
Tempered
  - Ball stainless steel AISI 420C Nickel plated
  - Spring element plastic (PUR) (Type BR)
  - Hexagon nut ISO 4035 (DIN 439) Stainless steel

- [Elastomer Characteristics](#) → Page 2158
- [Stainless Steel Characteristics](#) → Page 2166
- **RoHS**

**Information**

Clamping pads GN 709.3 / GN 709.35 are used as movable supports or plungers for clamping workpieces. They can also be used as stops.

After the clamping process, the contact surfaces of clamping pads automatically reset themselves to their initial position. This prevents the bearing from jamming in an inclined position when the workpiece is inserted.

The bearing can be rotated by a maximum of 9° and is secured against further rotation.

see also...

- [Clamping Pads GN 709.1 \(with Threaded Stud\)](#) → Page 1128
- [Clamping Pads GN 709.8 \(with Threaded Stud, Adjustable\)](#) → Page 1133

**How to order (Steel)**

**GN 709.3-17-M10-R**

- 1 A/F<sub>1</sub>
- 2 d<sub>1</sub>
- 3 Type

**How to order (Stainless steel)**

**GN 709.35-24-M16-B**

- 1 A/F<sub>1</sub>
- 2 d<sub>1</sub>
- 3 Type