

1.1

1.2

1.3

1.4

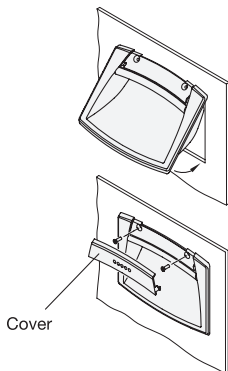

Mounting information

- 1) Drill the handle housing according to the template dimensions reported in the table.
- 2) Remove all drilling burrs before fitting the handle.
- 3) Fit the upper part of the handle into the housing and press onto the lower part until firmly in place.
- 4) Gently push the handle downward.
- 5) Fit the two self-tapping screws.
- 6) Assemble the screw cover by pressing on the lateral sides first and finally on the central part.

2.1

2.2

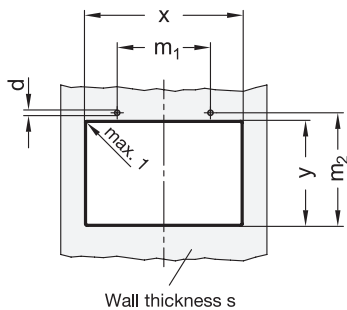

Wall thickness s	d ±0,02 for self-tapping screw	for M3	for b ₁ = 110				for b ₁ = 120			
			x +0,2	y +0,5	m ₁ ±0,1	m ₂ ±0,1	x +0,2	y +0,5	m ₁ ±0,1	m ₂ ±0,1
1 ... 1,2	2,5	Core hole drilling 2,5 Through bore-hole 3,2	100,5	52	64	55,5	107,5	73	64	76,8
> 1,2 ... 1,5	2,55		100,5	52,2	64	55,5	107,5	73	64	77
> 1,5 ... 2	2,6		100,5	52,5	64	56	107,5	73	64	77,2
> 2 ... 2,5	2,65		100,5	52,7	64	56,2	107,5	74	64	77,5
> 2,5 ... 3	2,65		100,5	53	64	56,5	107,5	74	64	77,8
> 3 ... 3,5	2,7		100,5	53,2	64	56,7	107,5	74	64	78,1
> 3,5 ... 4	2,7		100,5	53,4	64	56,9	107,5	75	64	78,4
> 4 ... 4,5	2,7		100,5	53,6	64	57,1	107,5	75	64	78,7
> 4,5 ... 5	2,7		100,5	53,8	64	57,3	107,5	75	64	79

2.3

2.4