

30x60 / 40x80 / 45x90

80x80 / 90x90

Countersink for socket cap screw
DIN 7984

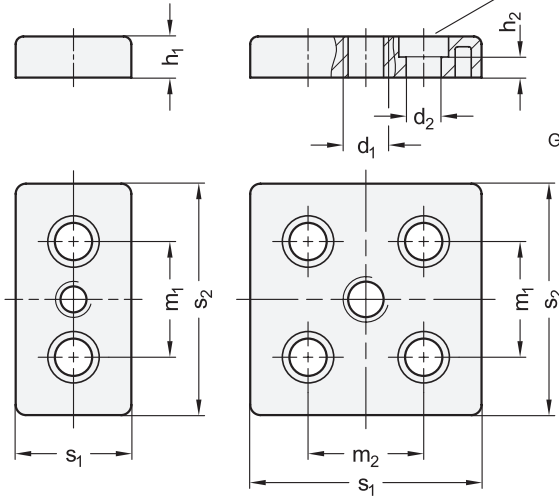

Application example

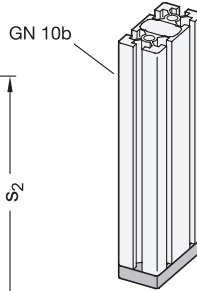

5 Type

A Without screws

1 s ₁	2 s ₂	3 n	4 d ₁		d ₂ For screw	h ₁	h ₂	m ₁	m ₂	Grid size
30	60	8	M 10	M 12	M 8 / S 8	12	3,2	30	-	30
40	80	10	M 10	M 12	M 12 / S 12	16	8	40	-	40
45	90	10	M 12	M 14	M 12 / S 12	16	8	45	-	45
80	80	10	M 12	M 16	M 12 / S 12	16	8	40	40	40
90*	90	10	M 16	M 20	M 12 / S 12	16	8	45	45	45

* Only compatible with profile type L

Specification

- Zinc die casting, black
- RoHS

6 ZS

Accessory

- Central Screws GN 21b → Page XYZ

Information

Transport and base plates GN 80b affix attachments such as leveling feet or castors to aluminum profiles.

They are installed in the profile holes on the end faces using suitably tapped threaded holes or thread-forming screws.

see also...

- Aluminum Profiles GN 10b (Profile Type Light) → Page QVX
- Aluminum Profiles GN 10b (Profile Type Heavy) → Page QVX

How to order	1 s ₁
	2 s ₂
	3 n
	4 d ₁
	5 Type
	6 Material / Color

GN 80b-459010M12-A-ZS



Assembly Instructions / Profile Machining

