

2 Type

- R** Clamping jaws at right angle to clamping arm
- P** Clamping jaws parallel to clamping arm

Mounting examples

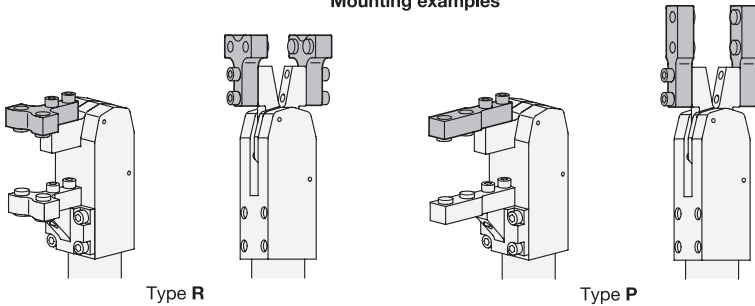

1

For power clamps Size	b -0,2	d ₁	d ₂ ^{H8/h6}	d ₃	d ₄ ^{H8/h6}	h ₁	h ₂	l ₁	l ₂	l ₃	l ₄	l ₅	l ₆	m ₁	m ₂	m ₃
20	10	M 6	9	M 5	7	10	10	37	30	54	13	18,5	19,5	12	14,5	17
32	12	M 8	11	M 6	9	12	14	53	40	76	17	23,5	29,5	18	20,9	23
40	16	M 10	13	M 8	11	14	16	63	50	93	20	28	34	22	23,5	30
50	18	M 10	13	M 10	13	16	18	73	60	113	20	28	34	27	28,5	40

Specification

- Steel C45
Chemically nickel plated **NC**
- Socket cap screws DIN 912,
Centering guide bushings
Steel, blackened
- ISO Fundamental Tolerances → Page 2151
- RoHS

3

Information

Holders for clamping jaws GN 868 are suitable for the clamping arms of the power clamps GN 864 / GN 865 / GN 866.

Holders for clamping jaws are equally precisely positioned on the clamping arm as are the clamping jaws GN 872 on the holders themselves.

When using type P, power clamps may be operated at up to a maximum of 6 bar.

Socket cap screws and centering guide bushings are included.

see also...

- Clamping Jaws GN 872 → Page 834

How to order

GN 868-16-R-NC

1	b
2	Type
3	Finish