

Wheel Tread, Materials

The following material options are available for the wheels: **Rubber**, **polyurethane**, **polyamide** and **phenolic resin**. These materials are explained below.

The **rubber** tread is made of natural rubber and/or synthetic rubber-based elastomer. It is applied to the wheel either via vulcanization or injection molding and has the following properties.

- + High elasticity and ease of movement
- + Gentle on floors
- + Low-noise
- + Vibration-damping
- High starting and rolling resistance
- Abrasion possible on rough floors

The **polyurethane** tread consists of an elastomer produced exclusively from synthetic materials. The polyurethane is applied to the wheel either by casting or injection molding and has the following properties.

- + Low starting and rolling resistance
- + High elasticity
- + Good resistance to wear and tear
- + Gentle on floors
- + Leaves no marks
- + Resistant to many aggressive media

On **single-part** wheels, the tread is determined by the base material of the wheel body; in other words, the tread and wheel core are produced from the same material in a single manufacturing process. The characteristic properties of the respective materials are explained below.

Polyamide:

- + Good resistance to wear and tear
- + Low starting and rolling resistance
- + Leaves no marks
- + Resistant to many aggressive media
- Can absorb and release moisture

Phenolic resin:

- + Heat resistant
- + Resistant to many aggressive media
- Lower wear and tearing resistance

Bracket Structure

When a wheel is combined with a bracket, this is referred to as a swivel caster or rigid caster, depending on the bracket type. The bracket is the connecting element between the wheel and the cart. The various types are swivel brackets, swivel brackets with total lock brakes and rigid brackets.

Swivel Bracket

The swivel bracket rotates around its vertical axis when the pushing direction changes. The wheel axle is offset from the bracket axis to provide for good maneuverability of the cart. Maneuverability refers to both the ability to steer the cart and to move in a straight line.

Swivel brackets are made up of the individual components of **mounting plate, wheel support fork, bearing, ball race ring, stud** (or center hole) and, depending on the design, a **dust seal**.

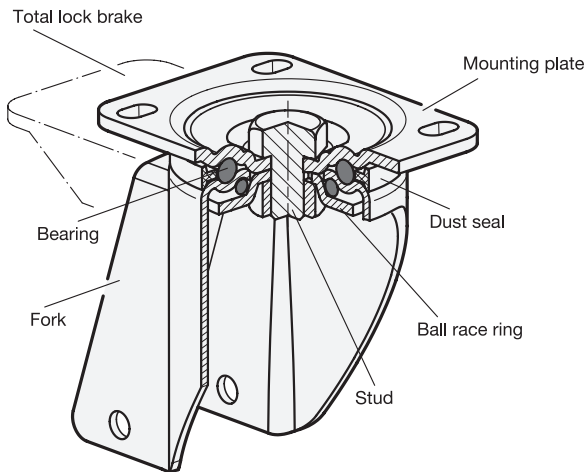

The **wheel support fork** holds the wheel via the wheel hub and is connected to the fitting plate by the bearing.

The **bearing** consists of a double axial ball bearing and allows the wheel support fork to rotate beneath the fitting plate. It is lubricated with grease and the **dust seal** protects it from dirt. The bearing is held together by the **stud** and the **ball race ring**, which forms the bottom surface.

The bracket is affixed to the cart via the **fitting plate**. The slotted holes make it easy to mount multiple casters in parallel.

A swivel bracket equipped with a **total lock brake** can be locked to prevent turning of both the wheel and the bracket.

Rigid Bracket

The rigid bracket consists of die-cut sheet steel and holds the wheel via the wheel hub. This combination is also called a rigid caster and helps keep the cart moving in a straight line.

